

SPEED WINCH

GE-SW/20/EF
~ 9,3 kg

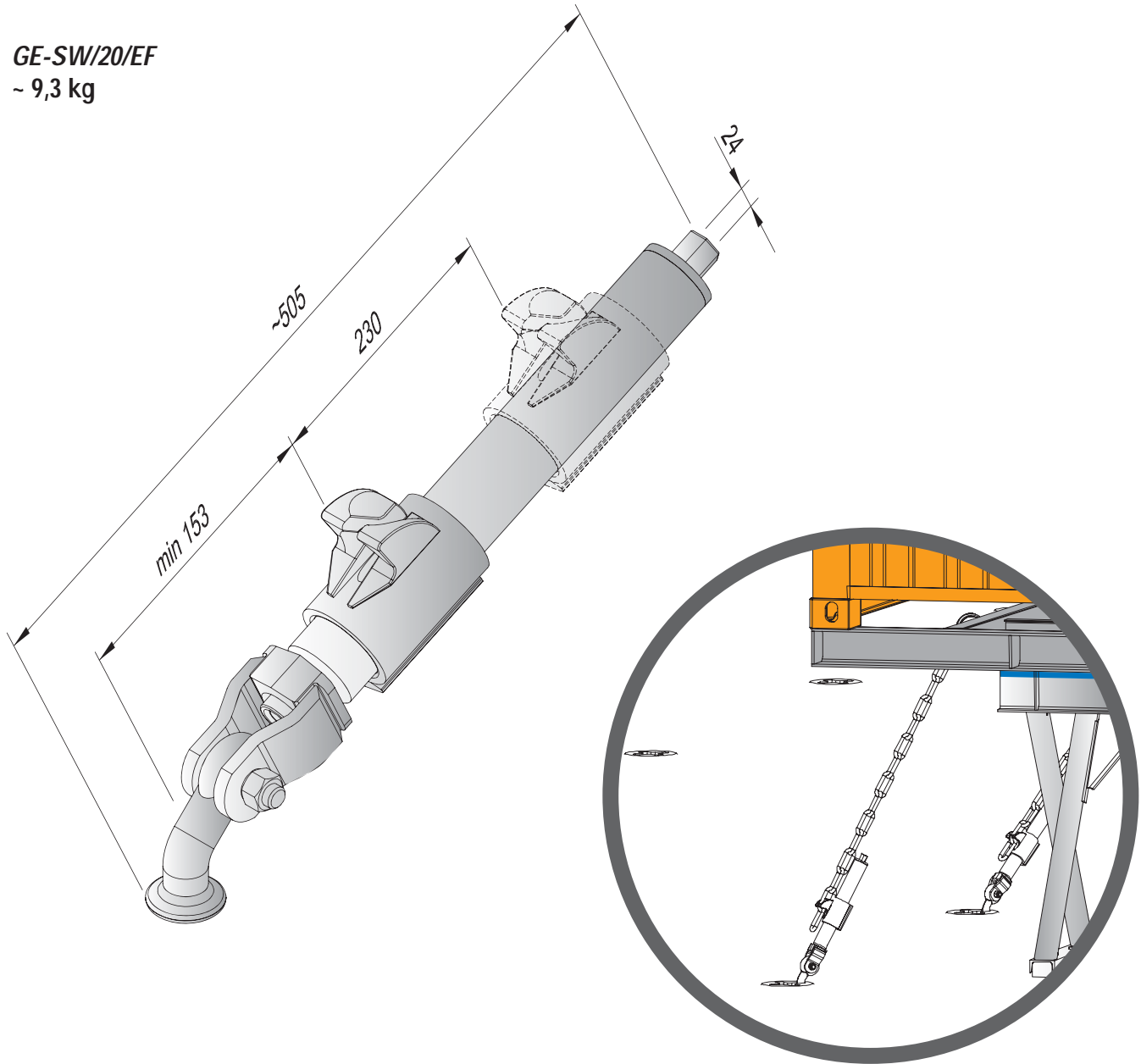

Specification

- Min. breaking load tension 20000 daN
- Suitable for long-link chain
- Can be operated with standard pneumatic or electrical power tools but also with manual ratchets
- Hot dip galvanised
- Long life lubrication
- Approval from any classification society
- Instead of elephant foot a hook can be applied at lower end