

## Lashing bars

**R-KS/...**

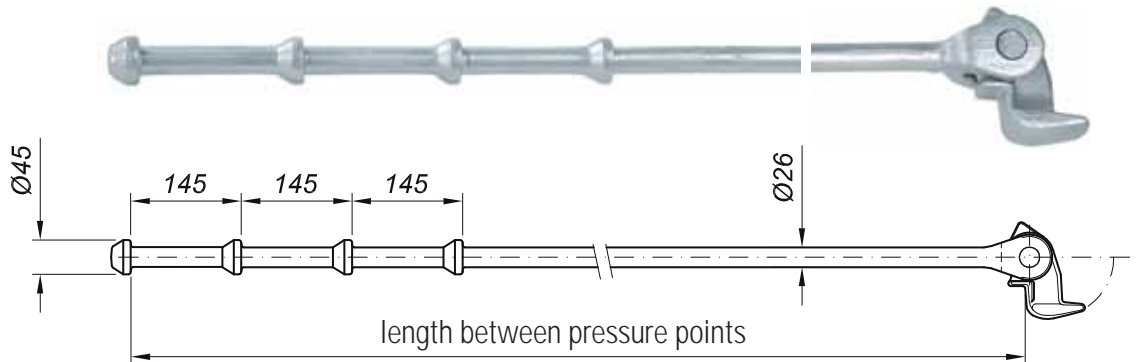

**R-KV/...**

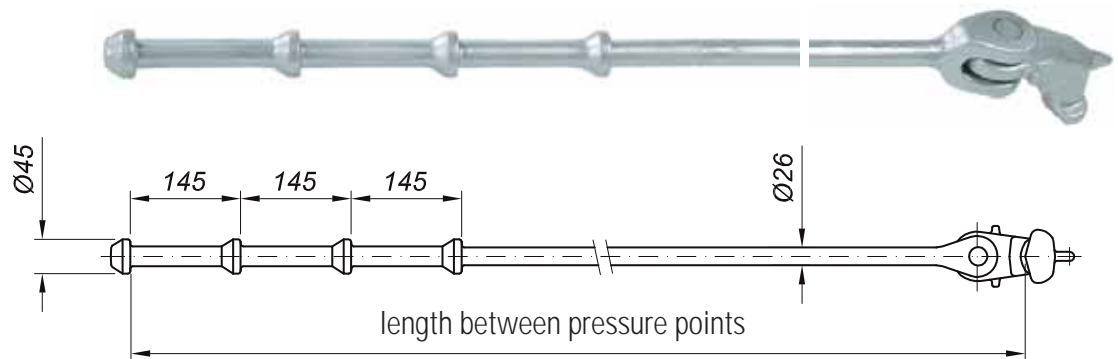

**Extension rod R-KN/...**

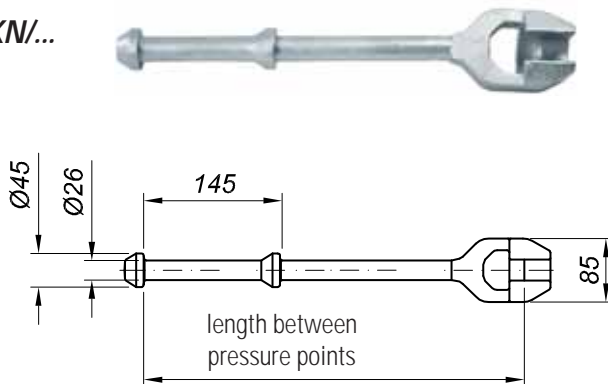

### Specification

- Min. breaking load tension 500 kN
- Approval from any classification society
- Swivel hook at upper end which is self-securing when the lashing bar is hanging in vertical direction.
- Made of high tensile steel
- Type R-KS/... (diagonal lashings) and R-KV/... (vertical lashings) with multiple knobs at lower end for fast pre-adjustment of length minimising necessary number of rotations when tightening the turnbuckles
- Under normal conditions the combination of long thread of turnbuckle and multiple knobs at lashing bar guarantees unified lashing length for all container heights. Only in case of unfavourable arrangement of lashing plates it might be necessary to apply additional extension rods at certain stack locations.
- Hot dip galvanised

## Lashing bars

*R-ES/...*

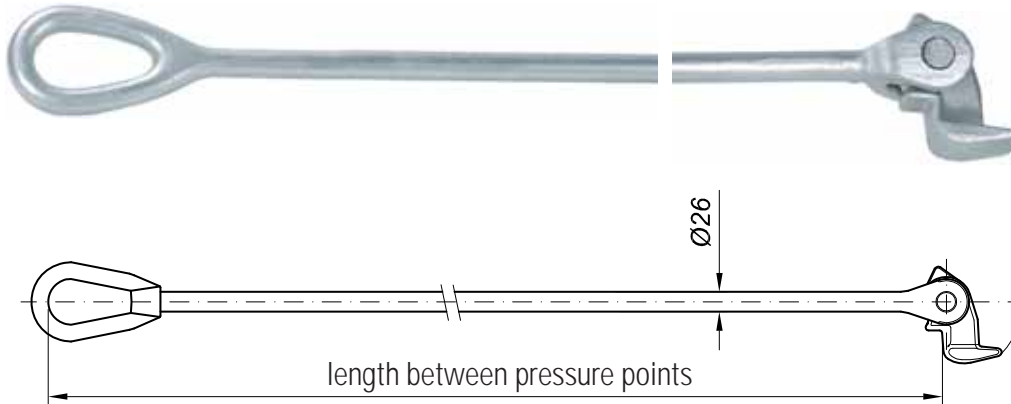

*Extensions rod R-EHS/305*  
~ 5,3 kg

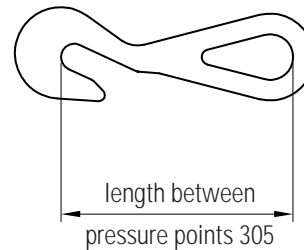
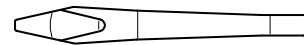

### Specification

- Min. breaking load tension 500 kN
- Approval from any classification society
- Swivel hook at upper end which is self-securing when the lashing bar is hanging in vertical direction.
- Made of high tensile steel
- Hot dip galvanised
- To be used preferably for spare parts deliveries